

A B C D E F G H I J

1
2
3
4
5
6
7

NOTES:

1.MATERIAL:

- 1.1 HOUSING: PA9T
- 1.2 DIELECTRIC: LCP
- 1.3 SHELL: ZAMAK3.
- 1.4 CONTACT: BRASS
- 1.5 BAFFLE: STAINLESS STEEL

2.FINISH:

CONTACT:

CONTACT: SEE ORDER INFORMATION.
 UNDERPLATING:50~100u" NICKEL OVERALL
 SHELL:120u"~240u" MATTE TIN

3.SPEC. PLS. REFER TO PS-92805-001xx-CAX.

4.PACKAGE PLS. REFER TO 92805-001xx-CAX-TRP.

5.PART NUMBER:

92805-001 X X-CAX
 CKTS 001: 1P
 PACKING 0:TAPE & REEL
 Coding: X:REFERENCE ON Page.2 TABLE
 PLATING 1: 6u" GOLD

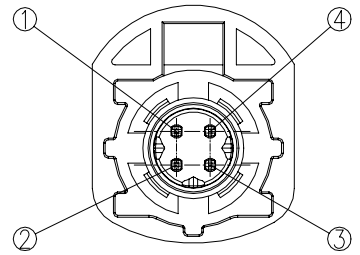
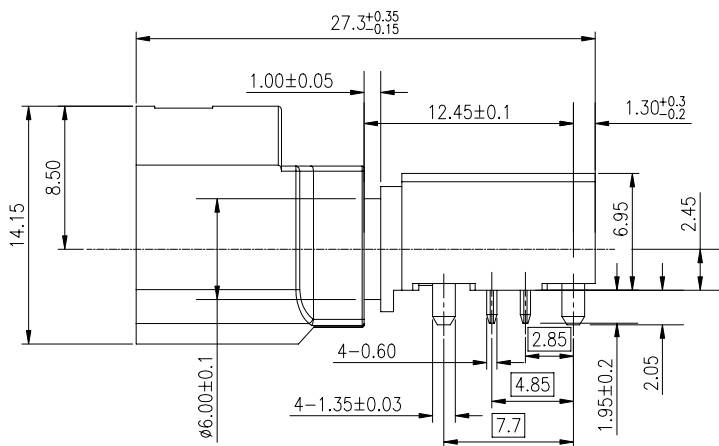
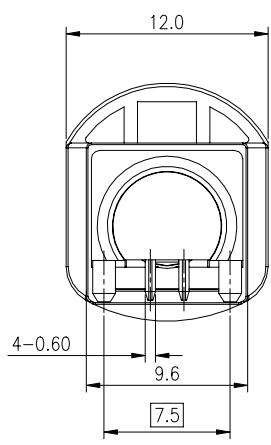

PINNING

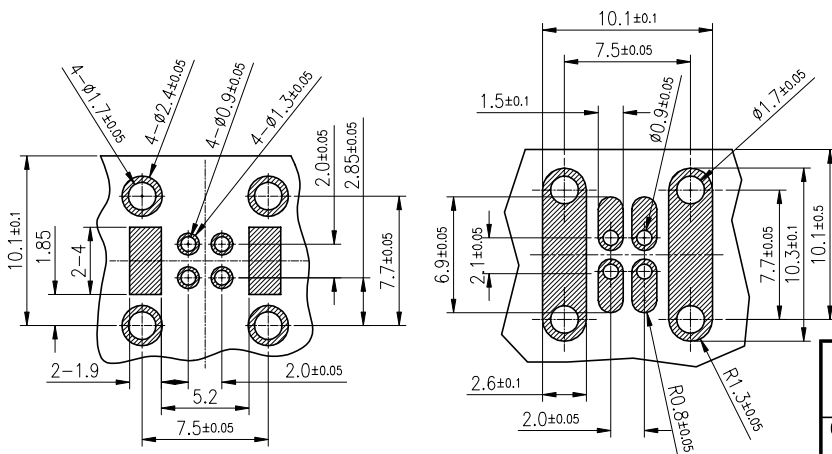



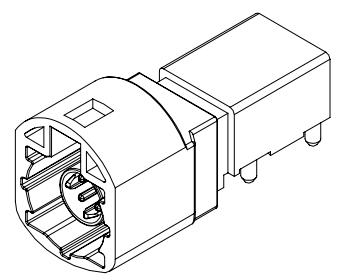

PCB LAYOUT

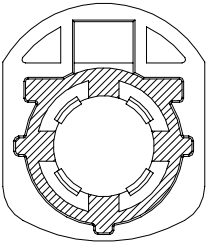
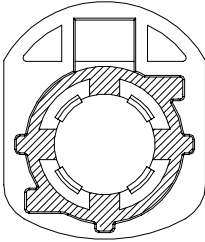
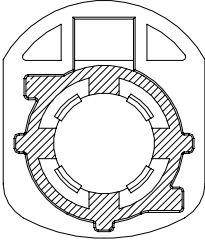
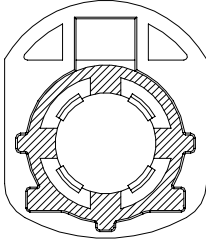
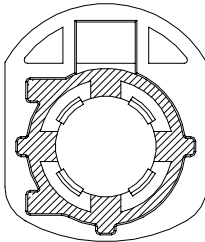
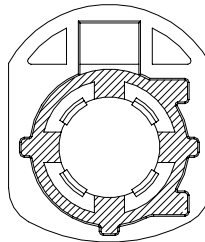
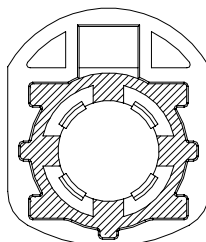
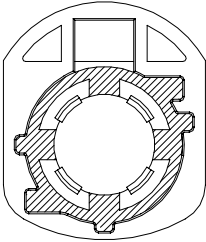
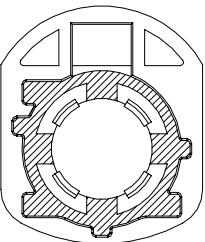

QUALITY SYMBOLS MAJOR Ⓢ CRITICAL Ⓢ GENERAL TOLERANCES (UNLESS SPECIFIED) X. ±0.50 .X ±0.25 .XX ±0.15 .XXX ±0.10 ANGLES ±1°	DRAWN BY Chen Chih Wei	DATE 21'/12/25	ACES ELECTRONICS TITLE HSD MALE CONN.T/H R/A SINGLE TYPE
	CHECKED BY Lee Kuang En	DATE 21'/12/25	
	APPROVED BY Chen Chi Chang	DATE 21'/12/25	R/FQ NO. NA
	UNITS mm		REV B
	SCALE 1 : 1	SHEET NO. 1 OF 2	DWG NO. 92805-001xx-CAX

TABLE for Coding:

Coding	A	B	C	D	E	F	Z
Plug							
Color	BLACK	WHITE	BLUE	BORDEAUX	GREEN	BROWN	WATER BLUE
RAL	sim.9005	sim.9010	sim.5005	sim.4004	sim.6002	sim.8011	sim.5021
Coding	H	J					
Plug							
Color	VIOLET	BEIGE					
RAL	sim.4003	sim.1001					

QUALITY SYMBOLS MAJOR  CRITICAL  GENERAL TOLERANCES (UNLESS SPECIFIED) X. ±0.50 .X ±0.25 .XX ±0.15 .XXX ±0.10 ANGLES ±1°	DRAWN BY Chen Chih Wei	DATE 21/12/25		
	CHECKED BY Lee Kuang En	DATE 21/12/25		TITLE HSD MALE CONN.T/H R/A SINGLE TYPE
	APPROVED BY Chen Chi Chang	DATE 21/12/25	UNITS mm	SIZE A4
	SCALE 1 : 1	SHEET NO. 2 OF 2		REV B
			R/Q NO. NA	
			DWG NO. 92805-001xx-CAx	